

ATN 4X12°

S.W.A.T. RIFLESCOPE



u s e r ' s g u i d e

**AMERICAN
TECHNOLOGIES
NETWORK
CORP.**



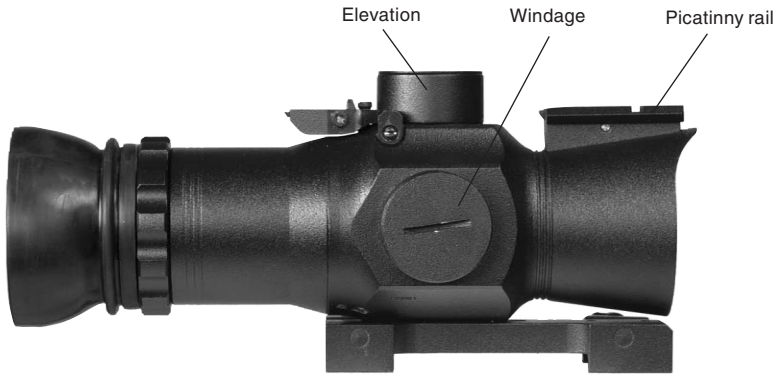
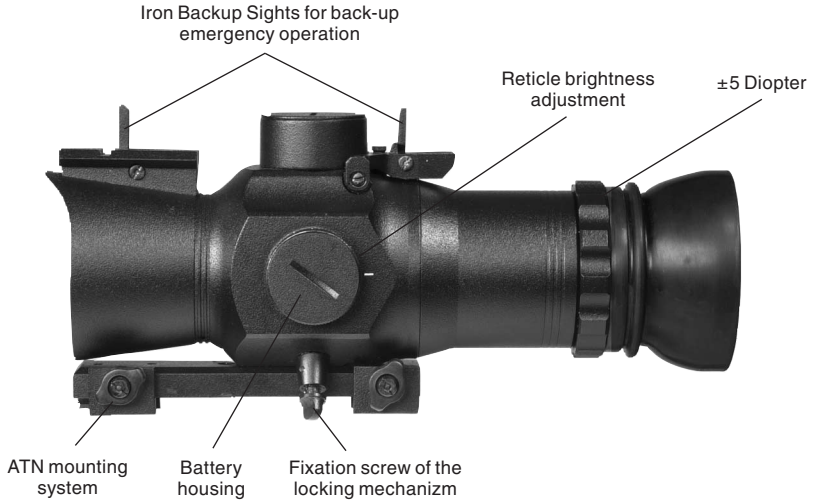

The information in this manual furnished for information use only, is subject to change without notice, is not to be construed as a commitment by ATN Corp.

ATN Corp. assumes no responsibility or liability for any errors or inaccuracies that may appear in this book.

©2003 ATN Corp. All right reserved.

APPLICATION

Intended for tactical LE and military marksmen the revolutionary ATN Super Wide Angle Tactical (SWAT) Scope is designed and made for professional firearms such as the AR15, M16 and M4.

One of the most desired parameters for a tactical scope is the Apparent Field of View (Magnification X FOV in degrees) for fast target acquisition and tracking of moving targets. Taking the AFV concept further than Trijicon ACOG (3.5x7=24.5) and Elcan (3.5x8=28) the ATN SWAT Scope has an AFV of 4x12=48(!) and the

Leupold Mark4 CQ/T does not even enter the competition.

The Swat scope also has an abundance of features like an illuminated reticle with 12 settings to match any light conditions without overwhelming your natural low-light vision (reticle is visible when not illuminated i.e. no batteries required).

Combining the strengths of an illuminated reticle sight with an unparalleled field of view the SWAT scope is perfect for tactical situations.

FEATURES

- **Magnification:** Fixed 4X.
- **Objective Aperture:** 30mm.
- **Construction/Materials:** Composite structure using aircraft aluminum alloy, high-carbon steel alloy and titanium inserts with 2mm wall minimum.
- **Optics:** Highest grade heavy glass; all elements and surfaces are multicoated; developed with latest optical software and manufactured with topmost tolerances for high resolution sharp clear image.
- **Reticle:** Tactical Ring and Dot reticle (very quick up close, and the four power magnification is useful at longer range); Illuminated with 12 rheostat positions; visible and operational if illumination is turned off; standard side locking mechanism.
- **Point of impact:** Always on the center of the field of view.
- **Field of View @ 4X:** 12°
 - 63ft at 100 yards (21 meters at 100 meters),
 - 315ft at 500 yards (105 meters at 500 meters).
- **Exit Pupil @ 4X:** 7.5mm.
- **Eye Relief:** 2" (50mm); specialized eye relief optimized for M16 variant cheek weld (allows to mount the scope in the conventional middle receiver position).
- **Diopter Adjustment:** +5/- 5; Adjustable Diopter Eyepiece system.
- **Adjustment:** 1/8 MOA "positive click" increments;
 - with 950 clicks, 9.5 revolutions with 100 clicks per revolution and 120 MOA of total elevation adjustment;
 - with 475 clicks, 4.75 revolutions with 100 clicks per revolution and 60 MOA of total elevation.
- **Power source:** 3V; standard watch battery type CR2032 or CR2432; with minimum 100 hours of continuous use.
- **Length:** 9" (227mm).
- **Weight:** 36.4oz (1.1 kilo) with built-in mounting system.
- **Sunshade:** Standard built-in.
- **Front Lens Cover:** Included.
- **Mounting system:** Built-in monorail with ejection cavity and thumb-screws for tool-less mounting to MIL-STD-1913 rail bases.
- **Environment:** waterproof up to 66 feet (20 meters) up to 1 hour; fog-proof and nitrogen purged.
- **Added Survivability:** Built-in standard adjustable Iron Backup Sights for back-up emergency operation.
- **Operational Extendibility:** 2" Picatinny rail for additional lighting, laser and other mission critical tools.

OPERATING

MOUNTING

1. Slightly loosen the fixing screws on the weaver rail built into the scope.
2. Place the scope on the dovetail mount of the fire arm making certain that the mount aligns with the receptor attachment screw groove. Adjust as necessary.
3. Tighten the fixing screws.

NOTE: Receptor attachment screws may need to be tightened after continuous shooting.

The ATN Mounting System allows to change the position of the riflescope flexibly on the weapon in relation to a shooter

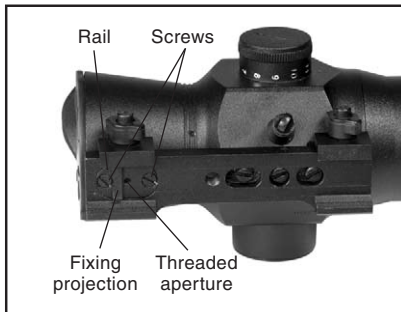

by 1/3 of inch. Such positions are additional to the fixed positions already available on the weaver rail. For this purpose in the base of the mounting bracket there is a rail with a fixing projection. For doing this one needs to about-face the rail.

To change the position of the riflescope on the weaver rail additionally follow the steps mentioned below:

1. Unscrew the two screws, which attach the rail to the mounting bracket.
2. Take the rail out of the groove.
3. About-face the rail in case of necessity.
4. Place the rail into another groove.
5. Fix the rail with the two screws.

NOTE: If the rail is not taken out easily, screw up tight one of screws into the threaded aperture in the middle of a fixing projection of the rail. Continue rotation of the screw. Thus the screw will push out a rail from a groove.

FOCUSING

While holding the scope about two inches from your eye, quickly glance through the eyepiece at a featureless, flatly lit bright area such as a wall or the sky.

CAUTION: Viewing the sun can cause serious eye injury, never look at the sun with this product or even the naked eye.

If the reticle is not sharply defined instantly, turn the eyepiece (either direction) a few turns.

Quickly glance through the scope again. If the focus has improved, but is still not perfect, continue focusing. If the focus condition become worse turn the focus the opposite direction.

LOCKING MECHANISM

There is a locking mechanism with fixation screw for windage/elevation adjustment and zeroing mechanism.



Slightly loosen the fixation screw before zeroing or windage/elevation adjustment.

After zeroing or windage/elevation adjustment turn the fixation screw clockwise, to lock the adjustment mechanism.

WINDAGE AND ELEVATION

The vertical and horizontal adjustments for the ATN 4X12° SWAT can be achieved by turning the elevation and windage adjustment mechanisms (remove dust caps first). Each click equals to 1/8 inches

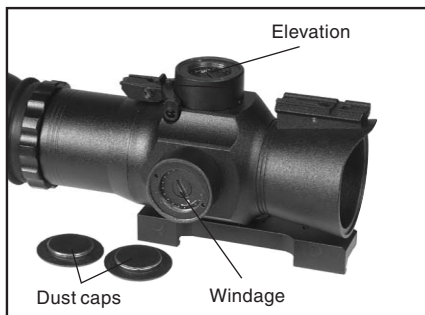

at 100 yards. When reaching the maximum of rotation do not use force.

ZEROING

Pre-zeroing is recommended and can be done in accordance with a scope guide or owner's instructions.

CAUTION: *Be sure gun is not loaded. Always use safe gun handling procedures.*

All shooting should be done at an approved range or other safe area. Eye and ear protection is recommended.

DANGER: *If you used a bore-obstructing device, remove it before proceeding. If the barrel has-been drilled for a mount, check that the screws do not protrude into the bore. Do not fire live or even blank ammunition with an obstructed barrel. An obstruction can cause serious damage to the gun and possible injury to you and others nearby.*

From a steady position, fire three rounds at a target. Observe the impact errors and estimate the correction value. Adjust windage and elevation handles as needed to correct aim.

Remove the dust caps from the top of the windage and elevation adjusting handles. Turn the windage and elevation handles through the number of clicks necessary for an amendment.

NOTE: *Each click of adjustment changes bullet strike by the amount shown on the chart below.*

Windage/Elevation (inches of movement per click)

100 Yards	- 1/8"
200 Yards	- 1/4"
300 Yards	- 3/8"
400 Yards	- 1/2"
500 Yards	- 5/8"

When you have finished adjustment of fire, recap windage and elevation mechanisms.

ELECTRONIC RETICLE

Your scope has an electronic Tactical Ring and Dot reticle. There are 11 degrees of illumination. The rheostat is the knob located at the back of the scope. It is labeled with numbers OFF through 11. When the rheostat is set at OFF you will see a black etched reticle. The reticle will light up red electronically as you rotate the rheostat through the numbers, 11 being the brightest.

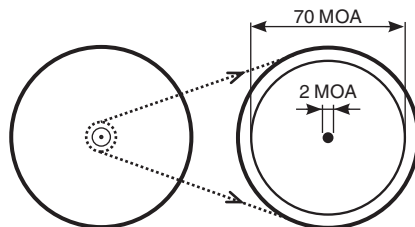

ADDED SURVIVABILITY

ATN 4X12° SWAT has a built-in visible flip-up Iron Backup Sights for back-up emergency operation. Upright the iron sights for shooting without optic of scope. The back-side sight has a horizontal and vertical adjustment.



MAINTAINING YOUR RIFLE SCOPE

Your rifle scope is waterproof and shock-proof. However, you should never try to take apart or clean it internally (it will void your warranty). If your scope ever does need repairs or adjustments, it should be returned to ATN's service department. The exposed optical surfaces will perform their best if they are occasionally wiped clean with a lens cloth or with optical quality lens paper like those for eyeglasses

or camera lenses. Maintain the metal surfaces of your rifle scope by removing any dirt or sand with a soft brush so as to avoid scratching the finish. Wipe down the scope with a damp cloth and follow with a dry cloth. Finally, going over the tube with a silicone treated cloth will restore luster and protect the scope against corrosion. Be careful not to touch the any of the lenses with the silicone cloth.

WARRANTY

LIMITATION OF LIABILITY

ATN will not be liable for any claims, actions, suits, proceedings, costs, expenses, damages or liabilities arising out of the use of this product. Operation and use of the product are the sole responsibility of the Customer. ATN's sole undertaking is limited to providing the products and services outlined herein in accordance with the terms and conditions of this Agreement. The provision of products sold and services performed by ATN to the Customer shall not be interpreted, construed, or regarded, either expressly or implied, as being for the benefit of or creating any obligation toward any third party of legal entity outside ATN and the Customer: ATN's obligations under this Agreement extend solely to the Customer. ATN'S LIABILITY HEREUNDER FOR DAMAGES, REGARDLESS OF THE FORM OR ACTION, SHALL NOT EXCEED THE FEES OR OTHER CHARGES PAID TO ATN BY THE CUSTOMER OR CUSTOMER'S DEALER. ATN SHALL NOT, IN ANY EVENT, BE LIABLE FOR SPECIAL, INDIRECT, INCIDENTAL, OR CONSEQUENTIAL DAMAGES, INCLUDING, BUT NOT LIMITED TO, LOST INCOME, LOST REVENUE, OR LOST PROFIT. WHETHER SUCH DAMAGES WERE FORESEEABLE OR NOT AT THE TIME OF PURCHASE, AND WHETHER OR NOT SUCH DAMAGES ARISE OUT OF A BREACH OF WARRANTY, A BREACH OF AGREEMENT, NEGLIGENCE, STRICT LIABILITY OR ANY OTHER THEORY OF LIABILITY.

PRODUCT WARRANTY REGISTRATION

In order to validate the warranty on your product, ATN must receive a completed Product Warranty Registration Card for each unit. Please complete the form below and immediately mail it to our Service Centre: ATN Corporation, 20 South Linden Ave. Suite 1B, South San Francisco, CA 94080. Products qualifying for warranty repair will be either repaired or replaced within 10 business days of receipt of merchandise unless the customer is notified otherwise.

OBTAINING WARRANTY SERVICE

To obtain warranty service on your unit, take or send the product, postage paid, with a copy of our sales receipt to our service centre, ATN Corporation at the address noted above. All merchandise must be fully insured with the correct postage; ATN will not be responsible for improper postage, or, missing or damaged merchandise during shipment.

LIFETIME LIMITED PRODUCT WARRANTY

This product comes with a Lifetime Guarantee against defects in both materials and workmanship. In the event a defect that is covered by the foregoing warranty occurs during the applicable period stated above, ATN, at its option, will either repair or replace the product, and such action on the part of ATN shall be the full extent of ATN's liability, and the Customer's sole and exclusive remedy. This warranty does not cover a product (a) used in other than its normal and customary manner; (b) subjected to misuse, (c) subjected to alterations, modifications or repairs by the Customer or by any party other than ATN without prior written consent of ATN; (d) special order or "close-out" merchandise or merchandise sold "as-is" by either ATN or the ATN dealer; or (e) merchandise that has been discontinued by the manufacturer and either parts or replacement units are not available due to reasons beyond the control of ATN. ATN shall not be responsible for any defects or damage that in ATN's opinion is a result from the mishandling, abuse, misuse, improper storage or improper operation, including use in conjunction with equipment which is electrically or mechanically incompatible with or of inferior quality to the product, as well as failure to maintain the environmental conditions specified by the manufacturer. This warranty is extended only to the original purchaser. Any breach of this warranty shall be waived unless the customer notifies ATN at the address noted below within the applicable warranty period.

THE CUSTOMER UNDERSTANDS AND AGREES THAT EXCEPT FOR THE FOREGOING WARRANTY, NO OTHER WARRANTIES WRITTEN OR ORAL, STATUTORY, EXPRESSED OR IMPLIED, INCLUDING ANY IMPLIED WARRANTY OF MERCHANTABILITY OR FITNESS FOR A PARTICULAR PURPOSE, SHALL APPLY TO THE PRODUCT. ALL SUCH IMPLIED WARRANTIES ARE HEREBY AND EXPRESSLY DISCLAIMED.



For customer service and technical support, please contact
American Technologies Network Corp.

North American Office

20 S. Linden Ave. Suite 1B, South San Francisco, CA 94080
phone: 800-910-2862, 650-875-0130; fax: 650-875-0129

European Office

phone: 44(0)870-0111286, fax: 44(0) 845-3349142

The following countries can use our
toll free number 00 800 9102-8620

Austria, France, Germany, Holland, Italy, Spain, Sweden, Switzerland

www.atncorp.com